

MATERIALS LIST

3"x 2" .188" wall	8' 0" (96 inches)	Wheel mounts
3"x 3" .188" wall	19' 4" (232 inches)	Base & uprights
3"x 3" .188" wall	2' 4" (28 inches)	Sleeves
2"x 2" .125" wall	12' 0" (144 inches)	Angled braces
2.5"x 2.5" .188" wall	17' 4" (208 inches)	Attachment bracket
3.0" OD .188" wall DOM	12"	Rotating sleeve
2.5" OD .250" wall	2' (24 inches)	Rotating pin
1/2" plate steel	10" x 10" square	Base gussets
1/4" plate steel	1.5" x 3" rectangle	Bracket gussets

Notes:

All casters: 4" Polyurethane (Caster Connection Part No. C3240-PU-S)
 1/4-28 holes: insert grease fittings (2 per rotating sleeve, 1 each side)
 All holes aligned unless otherwise noted.
 Add anchor pin locator holes as necessary for individual vehicle fitment.
 All welds triple-pass

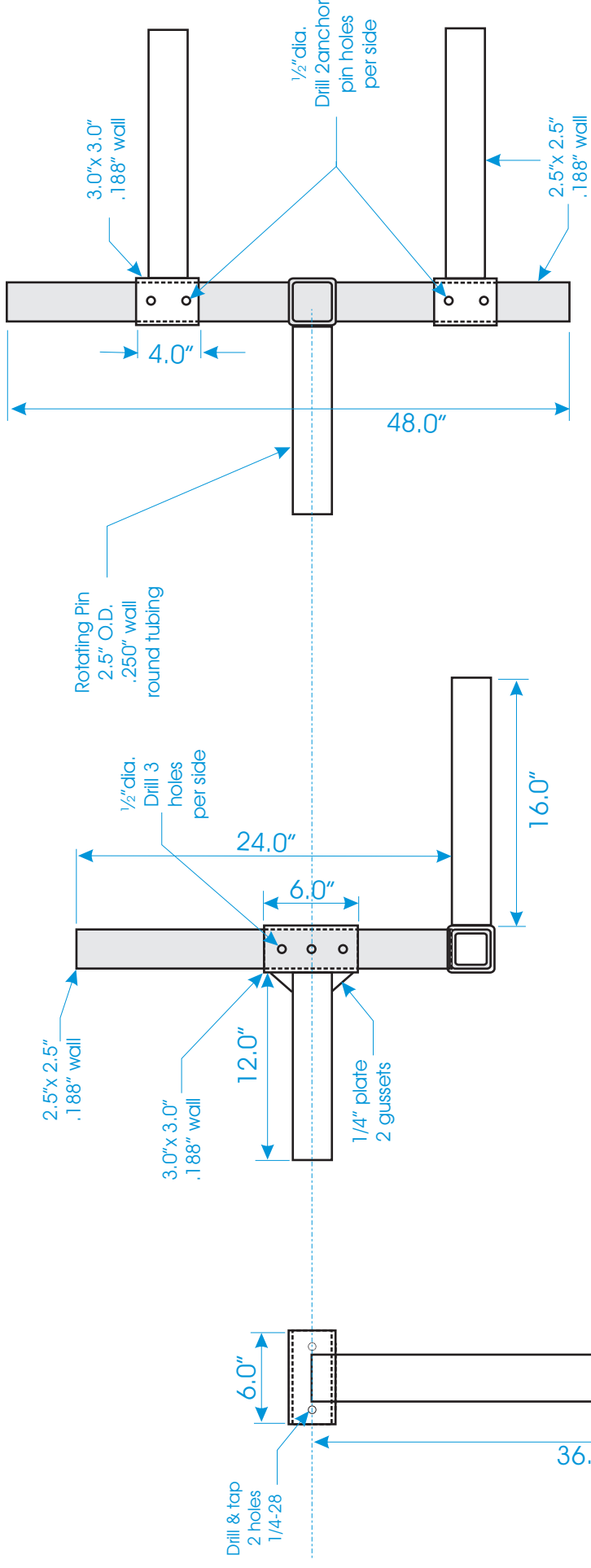

TOP VIEW

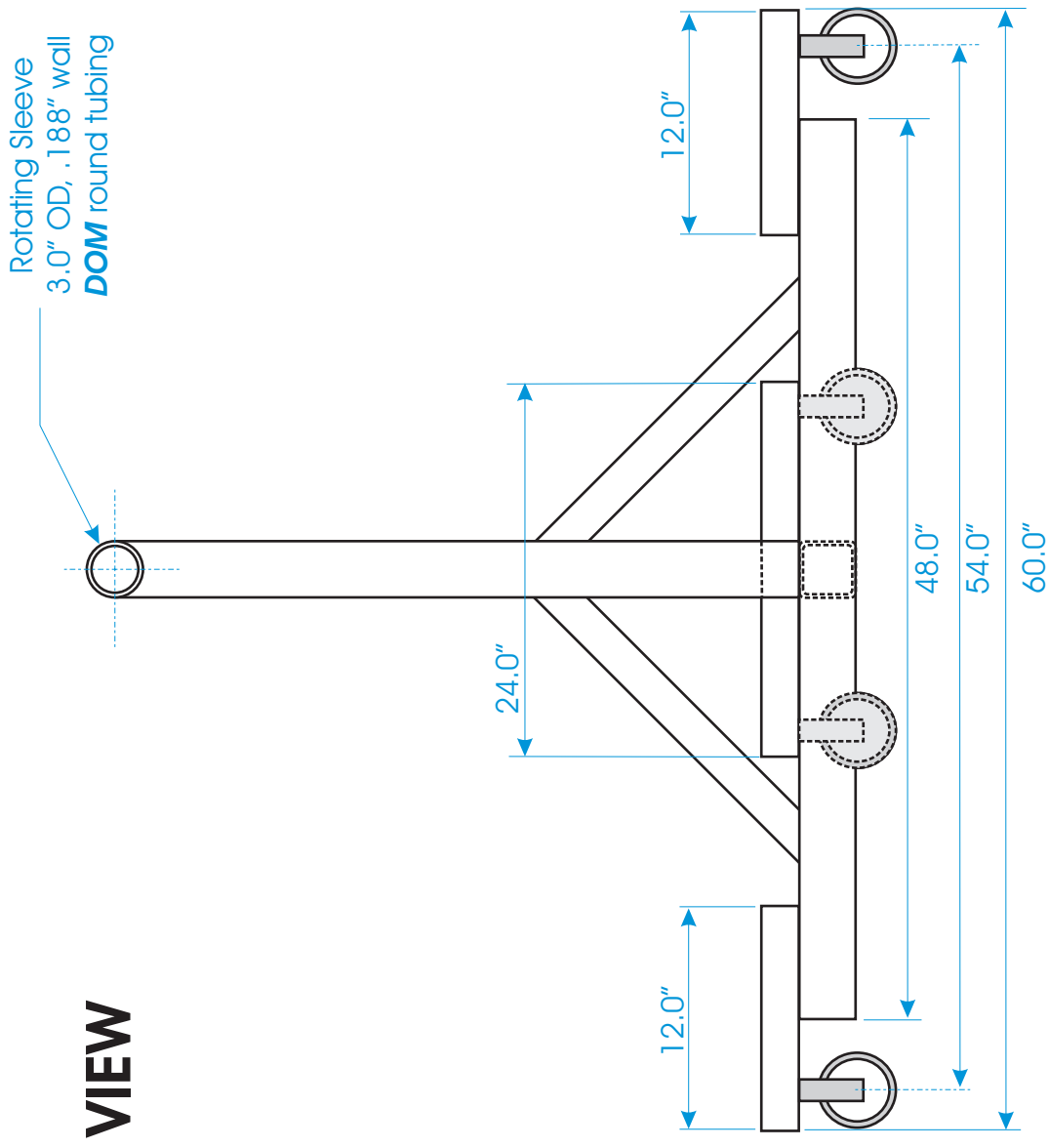

Drawn By: M. Harwood (www.harwoodperformanc.bizland.com)
Date: 8/9/04
© 2004 Harwood Performance Engineering. all rights reserved
WARNING: Alteration or modification of this drawing is strictly prohibited. Any changes must be examined and approved by a licensed structural engineer. Failure to do so can result in severe damage, injury or death. HPE is not responsible for damage or injuries arising from the use of this document.